

DD2000GT

HIGH SPEED TWISTING OF MONOFILAMENTS AND TAPES FOR ARTIFICIAL GRASS

- » Twisted bobbins with transfer tail for a more continuous downstream process
- » Bobbin formation with precision winding for an increased downstream process speed
- » Meter counting for equal bobbin length
- » Individual control of all twisting positions to have the necessary flexibility

Material / application	Monofilaments and Tapes for artificial grass
Material***	LLDPE, PP, BiComponent
Denier range *	6,000 up to 16,000 dtex
Spindle speed*	2,000 up to 6,000 rpm
Turns per meter**	20 up to 150
Take-up speed*	70 up to 250 m/min

* max. values cannot be combined
 ** depends on spindle speed and denier
 *** others on request

Supply bobbin (flanged bobbin)	
Max. bobbin diameter	300 mm
Max. stroke	280 mm*
Inner tube diameter	73 up to 110 mm
Twisted bobbin	
Max. bobbin diameter	300 mm
Inner tube diameter	73 mm*
Stroke	260 mm*

* others on request

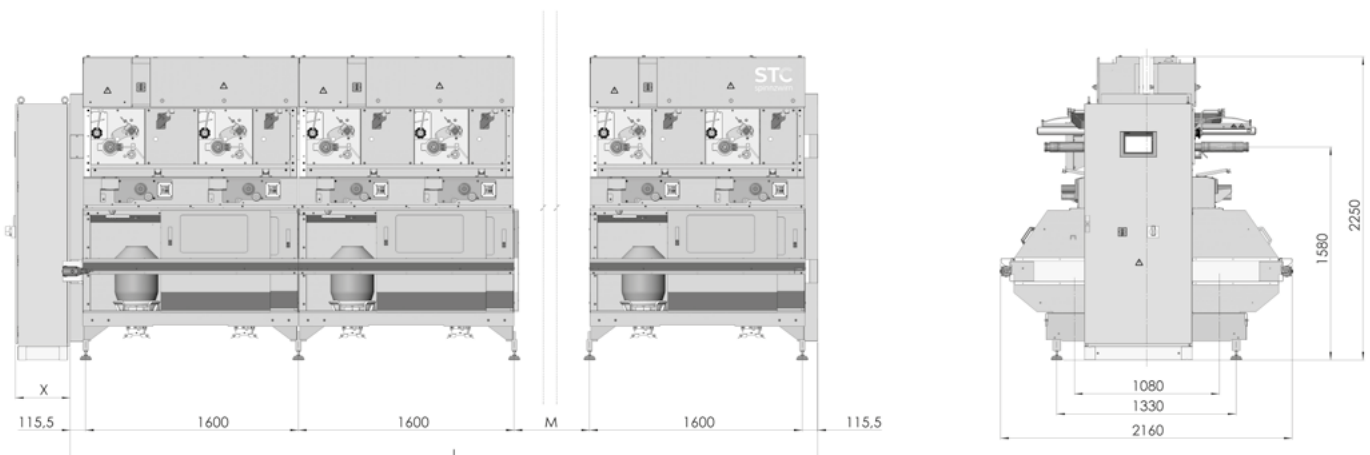



Textile machinery and
equipment from Chemnitz

A member of Starlinger Group

stc-spinnzwirn.com

STC Spinnzwirn GmbH

Zwickauer Straße 247
09116 Chemnitz
Germany
+ 49 371 23 88 / 240
info@stc-spinnzwirn.com
stc-spinnzwirn.com

The information supplied in this
brochure is for guidance only.
We reserve the right to modify
it at any time.

Reprint only with expressed
Permission of STC Spinnzwirn